



22126201



International Baccalaureate®
Baccalauréat International
Bachillerato Internacional

**DESIGN TECHNOLOGY
HIGHER LEVEL
PAPER 1**

Tuesday 8 May 2012 (afternoon)

1 hour

INSTRUCTIONS TO CANDIDATES

- Do not open this examination paper until instructed to do so.
- Answer all the questions.
- For each question, choose the answer you consider to be the best and indicate your choice on the answer sheet provided.
- The maximum mark for this examination paper is *[40 marks]*.

1. Which model would be most appropriate to evaluate the forces acting on a bridge structure?
 - A. Scale model
 - B. Prototype
 - C. Mathematical model
 - D. Clay model

2. Ron Hickman – a do-it-yourself enthusiast – damaged a chair he was using to support a piece of wood he was sawing. This gave him an idea for a work bench which became the Workmate (Figure 1).

Figure 1: Black and Decker Workmate



[Black & Decker Workmate 425[®]. Used with permission.]

What ideas generating technique is this an example of?

- A. Analogy
- B. Adaptation
- C. Constructive discontent
- D. Brainstorming

3. Which combination of “incremental design” and “radical design” characterizes many design problems?

	Incremental design	Radical design
A.	No	No
B.	No	Yes
C.	Yes	No
D.	Yes	Yes

4. **Figure 2** shows some of the symbols used in flowcharts. Which symbol would be used to represent a decision?

Figure 2: Flowchart symbols

A.



B.



C.

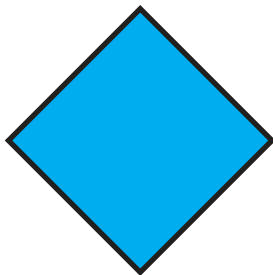

D.



5. **Figure 3** shows an analysis of competing products in terms of price and quality. Each blue dot represents an existing product.

Figure 3: Cost versus perceived quality for a range of competing products

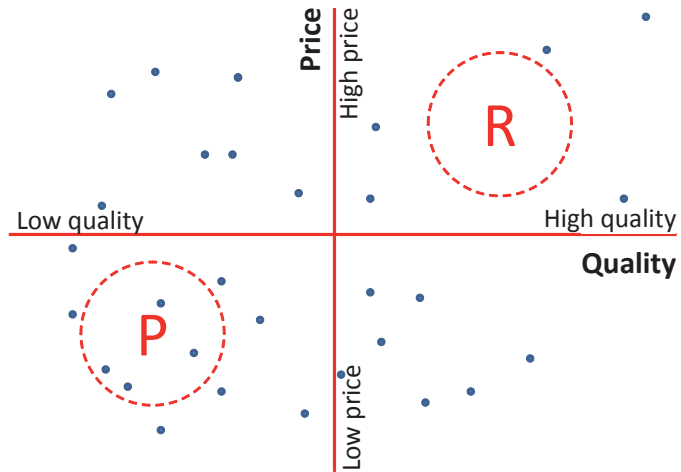

Why is a manufacturer more likely to develop a new product in region R rather than region P?

	Potential profit	Competition
A.	Lower	Low
B.	Lower	High
C.	Higher	Low
D.	Higher	High

6. The QWERTY typewriter keyboard (**Figure 4**) was designed by Christopher Latham Sholes around 1870 to speed up typing and is now the most widely-used keyboard layout on most English-language computers (**Figure 5**).

Figure 4: Sholes' 1878 QWERTY keyboard design

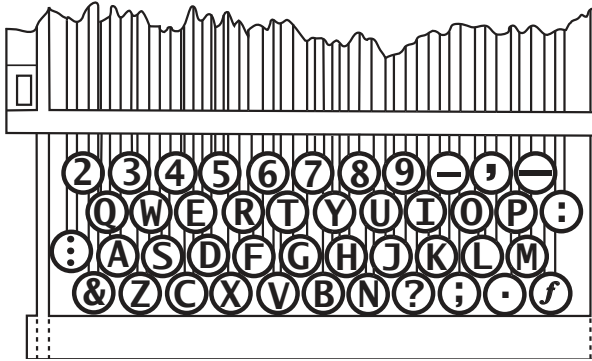

[Source: Adapted from: http://en.wikipedia.org/wiki/File:QWERTY_1878.png, Author: C.L. Sholes, U.S. Patent No. 207,559, 27 August 1878]

Figure 5: QWERTY design on computer keyboard



[From: http://en.wikipedia.org/wiki/File:QWERTY_keyboard.jpg; created by MichaelMaggs.]

Why did the QWERTY keyboard become the dominant design for English-language computer keyboards?

- I. It reduced the cost of retraining.
 - II. The mechanical keys do not jam.
 - III. It helped the transition from typewriter to computer.
- A. I and II
 - B. I and III
 - C. II and III
 - D. I, II and III

7. At which stage of the product cycle (**Figure 6**) do most changes to a product usually take place?

Figure 6: Sales of a product over time at different stages of the product cycle

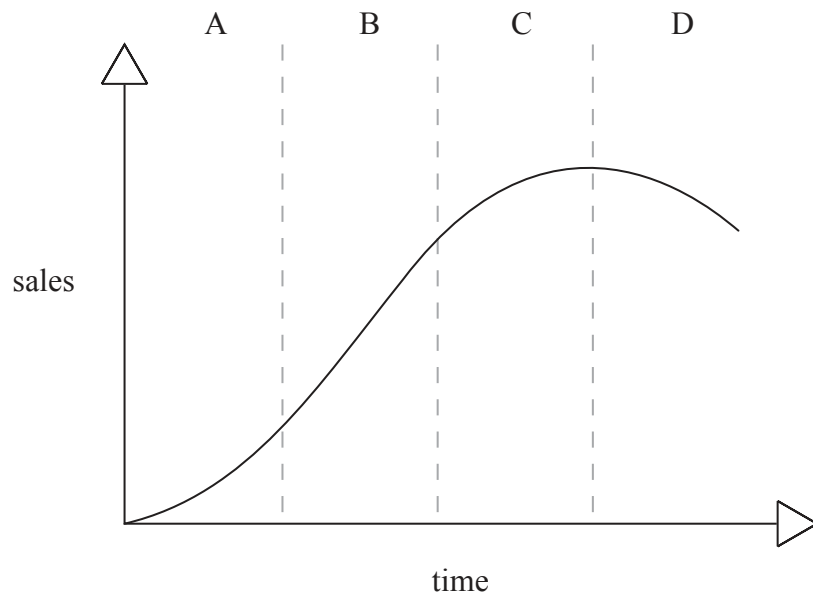

[Source: www.tomspencer.com.au/2009/01/25/product-life-cycle-model/]

8. Which combination of “environmental impact” and “market” makes it important that a product category undergoes life cycle analysis?

	Environmental impact	Market
A.	Low	Local
B.	Low	Global
C.	High	Local
D.	High	Global

9. Flybe is one of Europe's biggest regional airlines. In June 2007 Flybe pioneered the development of an eco-labelling scheme for aircraft (**Figure 7**). The label was modelled on those used for the sale of household appliances and shows a range of environmental indicators for particular aircraft. Flybe has published its methodology so that it can be used by other airlines.

Figure 7: The Flybe eco-label

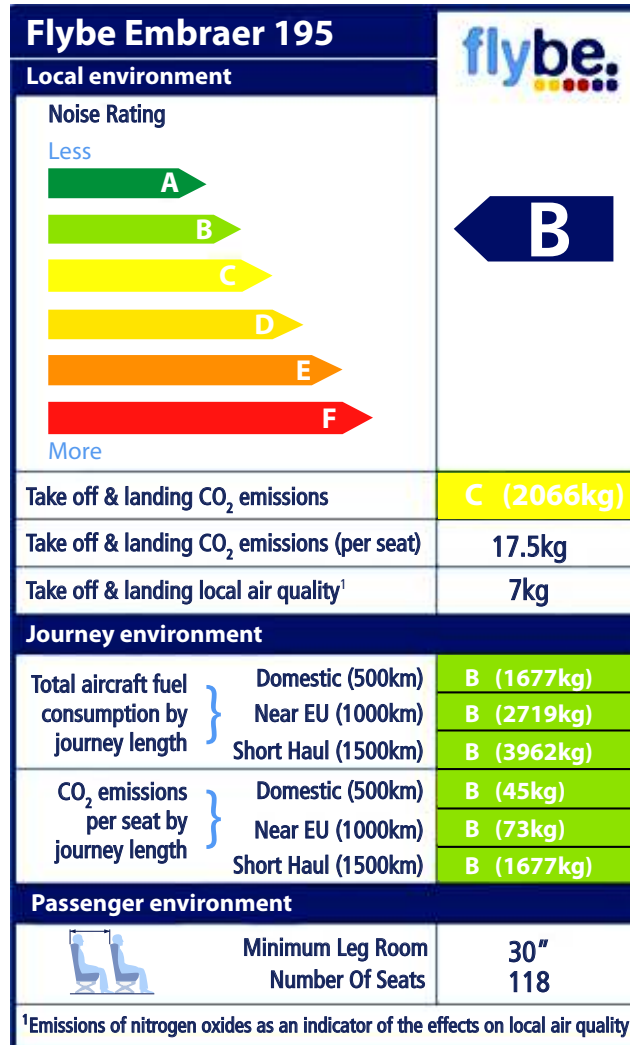

[Used with permission]

Why should all airlines use the same methodology to calculate the environmental impact of their aircraft?

- A. To improve the image of Flybe.
- B. To enable consumers to compare between different airlines.
- C. To assist the management of other airlines.
- D. To anticipate legislation.

10. What is most likely to increase as a result of the implementation of “take back” legislation for cars?
- A. Landfill costs
 - B. Product life cycle
 - C. Variety of materials used
 - D. Number of component parts
11. An alloy is defined as:
- A. the smallest part of an element that can exist chemically.
 - B. two or more atoms that are bonded together.
 - C. a mixture containing at least one metal.
 - D. a mixture of two or more substances with one acting as the matrix or glue.
12. **Figure 8** shows a cooking pot with a lid made of two dissimilar materials; glass and stainless steel.

Figure 8: Cooking pot



[Bueno cookware range from WMF. Used with permission.]

Which physical property is important when selecting materials for the lid of the cooking pot?

- A. Low hardness
- B. High thermal conductivity
- C. Low thermal expansion
- D. High density

13. **Figure 9** shows a hardwood (mahogany) external door.

Figure 9: Mahogany door



[Source: www.bdjoineryltd.co.uk/external-hardwood-pairs/churchill-glazed-hardwood-pai; Best Door Joinery, Ltd.]

Why would the door be treated with a transparent (varnish) finish rather than an opaque (paint) finish?

- A. Aesthetics
- B. Hardness
- C. Tensile strength
- D. Resistance to damp environments

14. **Figure 10** shows a copper tube being shaped using a pipe bender.

Figure 10: Copper tube and pipe bender

Content removed for copyright reasons.

[Please refer to this image http://www.northerntool.com/shop/tools/product_33396_33396]

Which characteristic is **not** demonstrated by the shaping of the copper tube?

- A. Plasticity
 - B. Malleability
 - C. Ductility
 - D. Elasticity
15. What is defined as the ability of a material to resist the propagation of cracks?
- A. Toughness
 - B. Hardness
 - C. Density
 - D. Ductility

16. What is a characteristic of covalent bonding?
- A. Sharing of electrons between atoms
 - B. Involves a metal and a non-metal
 - C. Nuclei in a sea of electrons
 - D. Loss and gain of electrons
17. What is a disadvantage of craft production?
- A. Quality is perceived to be higher
 - B. The cost of the product is often higher
 - C. Products are unique
 - D. There is often a close relationship between the craftsman and the client
18. Which costs will be higher per unit of product for craft production than for automated production?
- A. Capital costs
 - B. Labour costs
 - C. Raw material costs
 - D. Marketing costs
19. What characterizes an “end-of-pipe” approach to clean-up technology?
- A. Process modification
 - B. Product modification
 - C. Reduced release of toxic materials into the environment
 - D. Reduced waste production

20. What is **not** true of mass customization?
- A. Products can be customized to meet the needs of individuals
 - B. Customized products can be produced at competitive prices
 - C. Manufacturers can develop close relationships with customers
 - D. Products should be customized as early as possible in the manufacturing process
21. **Figure 11** and **Figure 12** show a roadable aircraft called Transition®. It is classified by aviation authorities as a light sport aircraft. Its wings fold at the touch of a button to convert into a car. Roadable aircraft have to meet motor vehicle regulations and aviation regulations. This results in conflicts which the designer must resolve.

Figure 11 and Figure 12: Transition® Roadable Aircraft

Content removed for copyright reasons.

[Please refer to: <http://www.terrafugia.com/images/LeavingGarageWM-Med.jpg>
<http://www.terrafugia.com/images/TransitionFlyingLookingUpWM-Med.jpg>]

Which of the following regulations for light sports aircraft would be a major constraint on the designer of the roadable aircraft?

- A. A maximum take off weight of 1320 pounds
- B. A maximum speed of more than 120 knots
- C. No more than two seats
- D. Fixed landing gear

22. What describes the product lifecycle for fashion and planned obsolescence?

	Fashion	Planned obsolescence
A.	Unpredictable	Unpredictable
B.	Unpredictable	Predictable
C.	Predictable	Unpredictable
D.	Predictable	Predictable

23. Which is an advantage of using a field trial to evaluate the design of a solar panel?

- A. Time
- B. Cost
- C. Sample size
- D. Testing in-situ

24. What is a limitation to the development of clean coal technology by manufacturers?

- A. Lack of research and development
- B. Diminishing coal reserves
- C. Lack of political will
- D. Lack of investment

25. The energy generated by a wind turbine is proportional to the area covered by the rotor blades (Figure 13).

Figure 13: Wind turbine



[Source: www.alternative-energy-news.info/technology/wind-power/wind-turbines/]

By what factor does the energy generated by the wind turbine increase if the length of the rotor blades is increased by 50%.

- A. 1.50
- B. 2.25
- C. 2.75
- D. 3.25

26. **Figure 14** shows the forces acting on a suspension bridge.

Figure 14: Forces acting on a suspension bridge

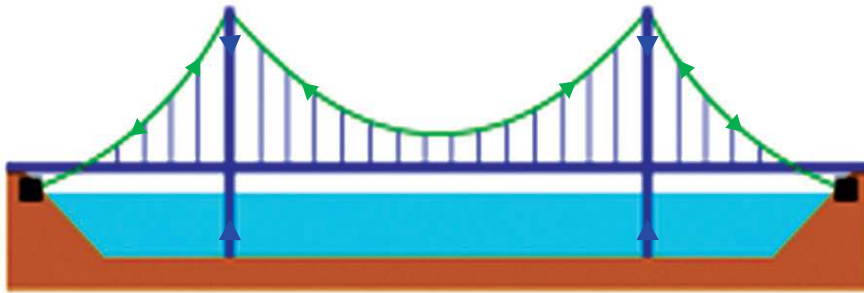

[From: <http://upload.wikimedia.org/wikipedia/commons/thumb/c/c0/Bridge-suspension-anchorages.svg/225px-Bridge-suspension-anchorages.svg.png>]

What is **not** true of the forces acting on the suspension bridge?

- A. Tensile forces > compressive forces
 - B. Tensile forces equal compressive forces
 - C. The towers of the suspension bridge are under compression.
 - D. The cables of the suspension bridge are under tension.
27. Which cam shape in **Figure 15** would cause a cam follower to rise gently and then fall sharply?

Figure 15: Cam profiles and cam followers

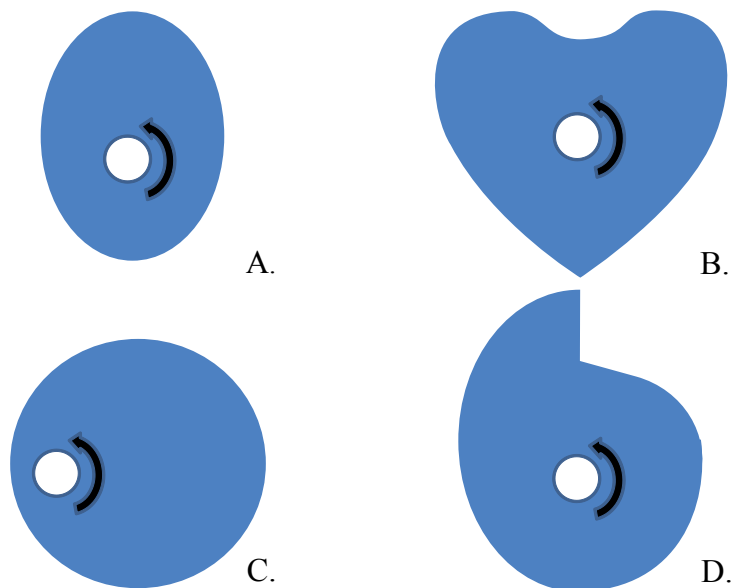

[www.technologystudent.com]

28. **Figure 16** shows a gear train in which C is the driver.

Figure 16: A gear train

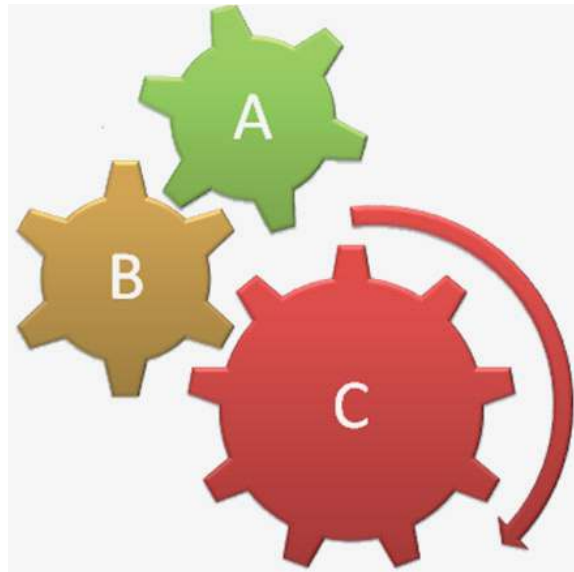

[www.technologystudent.com]

In which direction will gears A and B turn?

	Gear A	Gear B
A.	Clockwise	Clockwise
B.	Clockwise	Anticlockwise
C.	Anticlockwise	Clockwise
D.	Anticlockwise	Anticlockwise

29. Which manufacturing method uses thermosetting plastic?

- A. Vacuum forming
- B. Blow moulding
- C. Compression moulding
- D. Rotational moulding

30. Which combination of “temperature” and “pressure” is used in injection moulding?

	Temperature	Pressure
A.	Low	Low
B.	Low	High
C.	High	Low
D.	High	High

31. Which joining technique is consistent with design for disassembly?

- A. Pop-rivets
- B. Welding
- C. Brazing
- D. Thermoplastic adhesive

32. What promotes economic sustainability?

- A. Biodiversity
- B. Cultural identity
- C. Productivity
- D. Equity

33. What can be modified through the selection of different materials for the construction of a building envelope?

- A. Area
- B. Thickness
- C. Temperature difference
- D. Thermal conductivity

34. How does thermal mass in a building help overcome temperature fluctuations?

- A. Direct solar gain
- B. Indirect solar gain
- C. Heat storage
- D. Insulation

35. What are the likely timescales for “manufacturers” and “governments” in relation to return on investment in sustainable development?

	Manufacturers	Governments
A.	Short term	Short term
B.	Short term	Long term
C.	Long term	Short term
D.	Long term	Long term

Questions 36–40 relate to the following case study. Please read the case study carefully and answer the questions.

Figures 17 and **Figure 18** shows a lift (elevator). The lift car is raised and lowered by steel ropes. The ropes are attached to the lift car, looped around a pulley (3) and connected to a counterweight (4) on the other side of the pulley. Both the lift car and the counterweight ride on guide rails (5) along the sides of the lift shaft. The rails keep the car and counterweight from swaying back and forth.

The pulley has grooves around it and is connected to an electric motor (2). The pulley grips the ropes, so when it turns the ropes move too. When the motor turns one way it raises the lift; when it turns the other way it lowers the lift. The sheave, the motor and the control system (1) are all housed in a machine room above the lift shaft. The counterweight weighs about the same as the car when it is about half full (an average amount). The lift has been designed for eight users or a maximum load of 630 kg.

Figure 17: A lift mechanism

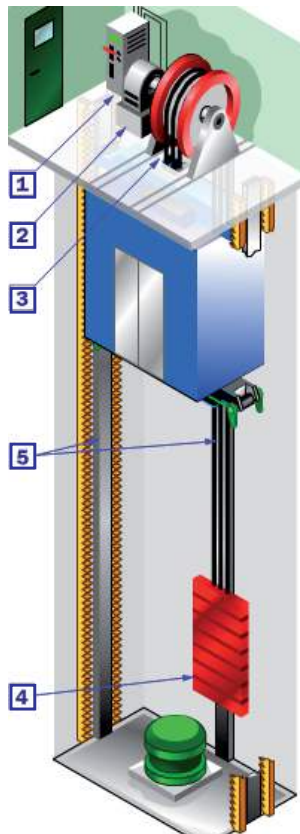

[Source: <http://science.howstuffworks.com/transport/engines-equipment/elevators3.htm>; www.howstuffworks.com]

Figure 18: An exterior glass lift



[www.graffitigossip.com; Sandra Miller]

36. What is a disadvantage of locating the lift on the exterior of the building in **Figure 18**?
- A. Maintenance
 - B. Aesthetics
 - C. Ergonomics
 - D. Safety

37. What is an advantage of the steel wire being twisted in to a rope for the lift cable?
- A. Increased elasticity
 - B. Increased tensile strength
 - C. Increased compressive strength
 - D. Increased stiffness
38. The advantage of using a pulley in this system is:
- I. To improve the mechanical advantage of the lift system.
 - II. To convert rotary motion into linear motion.
 - III. To improve the efficiency of the system.
- A. I and II
 - B. I and III
 - C. II and III
 - D. I, II and III
39. The lift is fitted with an alarm to indicate when it is overloaded. What triggers the alarm?
- A. Normal maximum load
 - B. Number of people
 - C. Design load
 - D. Total body load
40. What is an advantage of balancing the loads on either side of the pulley?
- A. It only takes a small force to operate the lift.
 - B. Electrical energy is converted to potential energy.
 - C. The lift car uses up potential energy as it descends.
 - D. The counterweight builds up potential energy as it rises.
-